

GENERAL LIGHTS

LEDOS
LIGHTING SOLUTIONS



01

BEAMUP HIGHBAY

Unveiling the BeamUp Highbay, an embodiment of cutting-edge LED technology designed to illuminate industrial and commercial spaces with unparalleled brilliance. Engineered for rugged environments, this Highbay luminaire is a beacon of reliability, ensuring unwavering performance in the harshest conditions. With an extraordinary lumen output, the BeamUp Highbay effortlessly transforms vast spaces with a radiant glow, enhancing visibility and productivity. Tailored for high ceilings, its exceptional light beam spread guarantees uniform illumination, eradicating shadows and creating an environment conducive to precision and efficiency.

Crafted to withstand the challenges of industrial landscapes, the BeamUp Highbay is not merely a luminaire but a robust lighting solution that stands the test of time. Elevate your environment with the BeamUp Highbay.



Beam Angle

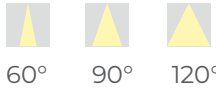

Applications

- Workshops & Assembly Lines
- Storage & Logistics
- Industrial & Commercial Halls
- Hangars
- Public Places - Airports & Stations

System Efficacy (lm/W)

>130lm/W

CCT

4000K, 5700K

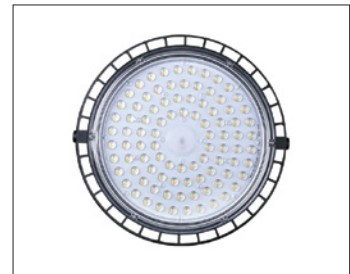
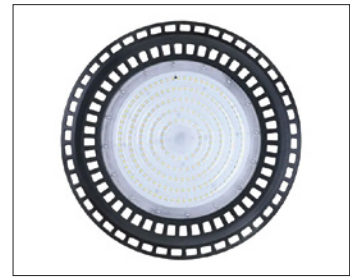

| Sizes | 326mm | 326mm | 326mm | 365mm | 365mm | 365mm |
|---------|--------|----------|----------|----------|----------|----------|
| Wattage | 55W | 90W | 120W | 160W | 200W | 240W |
| Lumen | 7150lm | 11,700lm | 15,600lm | 20,800lm | 20,800lm | 31,200lm |

Product Dimensions

Ø 326 x 160 mm

Ø 365 x 160 mm

Product Impression

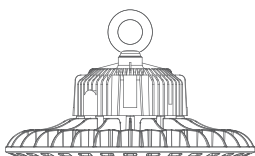
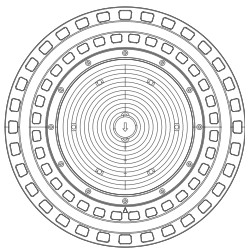

SDCM

<5 steps

Dimmable

ON/OFF , Dimmable 1-10V

Material

Aluminium + PC

Lamp Lumen Lifetime

50,000hrs @ L70/B50



02

EASYCOMFO LED PANEL

Introducing LEDOS EasyComfo LED Panel, the pinnacle of advanced LED lighting, tailored for commercial excellence. Boasting a formidable lumen output, this luminary is designed to elevate your workspace with unparalleled brightness and efficiency. Versatility is paramount, offering glare control properties with high-definition prismatic optics with recessed and suspension mounting options. EasyComfo LED Panel exemplifies precision engineering, delivering an exceptional and uniform & glare-controlled light beam spread that sets a new standard for commercial lighting solutions.

Experience brilliance like never before, as the EasyComfo LED Panel excels in light production, creating an ambiance that is both functional and visually stunning. With standard lumen outputs for selection, this luminary accommodates diverse lighting requirements.



Beam Angle



110°

Applications

- Office
- Banks
- Public Spaces
- Schools

System Efficacy (lm/W)

>110lm/W

CRI

>80 & >90

CCT

3000K, 4000K, 6000K



| Sizes | 1' x 4' | 2' x 2' |
|---------|---------|---------|
| Wattage | 40W | 40W |
| Lumen | 4400lm | 4400lm |

Product Dimensions

Ø 595 x 595mm

Ø 295 x 1195mm

Product Impression

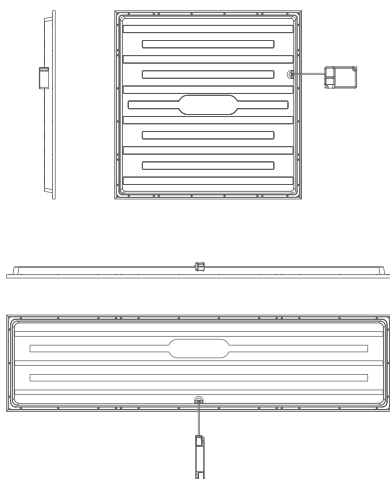

SDCM

<5 steps

Dimmable

On Request

Material

Aluminium Body + PMMA Diffuser

Lamp Lumen Lifetime

50,000hrs @ L70/B50

UGR

<19

Prismatic Optics



03

HERMETIC LOUVER IP65

Introducing LEDOS Hermetic Louver IP65, an exemplary LED lighting solution meticulously engineered to meet the stringent demands of industrial environments. Designed to prioritize hygiene, this luminary is a beacon of cleanliness and efficiency, ensuring that your ceiling spaces are brilliantly illuminated while upholding the highest sanitation standards. With a commanding lumen output, the Hermetic Louver IP65 guarantees optimal brightness, creating a well-lit environment essential for precision in manufacturing and working. Its exceptional light beam spread ensures uniform illumination even in the most complex and elevated spaces, enhancing visibility and productivity.

Its robust construction and adherence to sanitation norms make it the ideal choice for those operating in the Food and Pharma sectors where cleanliness is paramount.



Beam Angle



110°

Applications

- Hospitals
- Clean Rooms
- Kitchen & Workspaces
- Food & Pharma Production Sites
- Other Clean Production Areas

System Efficacy (lm/W)

>100lm/W

CRI

>80 & >90

CCT

4000K, 6000K

| Sizes | 1' x 4' | 1' x 4' | 2' x 2' | 2' x 2' |
|---------|---------|---------|---------|---------|
| Wattage | 40W | 56W | 40W | 56W |
| Lumen | 4000lm | 5600lm | 4000lm | 5600lm |

Product Dimensions

Ø 600 x 600 x 15mm

Ø 300 x 1200 x 15mm

Product Impression

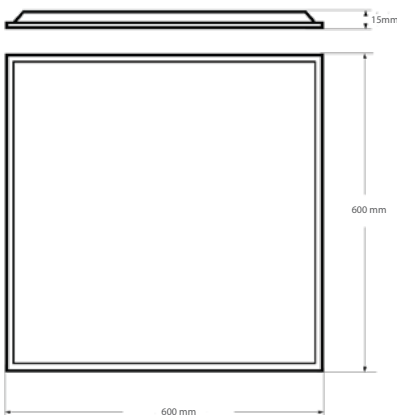

SDCM

<5 steps

Dimmable

On Request

Material

Aluminium Body + PMMA Diffuser

Lamp Lumen Lifetime

50,000hrs @ L70/B50

UGR

<22

IP65



04

COMPACT HIGHBAY FG

Introducing LEDOS Compact Highbay FG, an exemplary LED lighting solution meticulously engineered to meet the stringent demands of industrial environments, particularly in Food and Pharma-related production settings where sanitation reigns supreme. Designed to prioritize hygiene, this luminary is a beacon of cleanliness and efficiency, ensuring that your high-ceiling spaces are brilliantly illuminated while upholding the highest sanitation standards. With a commanding lumen output, the Compact Highbay FG guarantees optimal brightness, creating a well-lit environment essential for precision in manufacturing. Its exceptional light beam spread ensures uniform illumination even in the most complex and elevated spaces, enhancing visibility and productivity.

Its robust construction and adherence to sanitation norms make it the ideal choice for those operating in the Food and Pharma sectors where cleanliness is paramount.

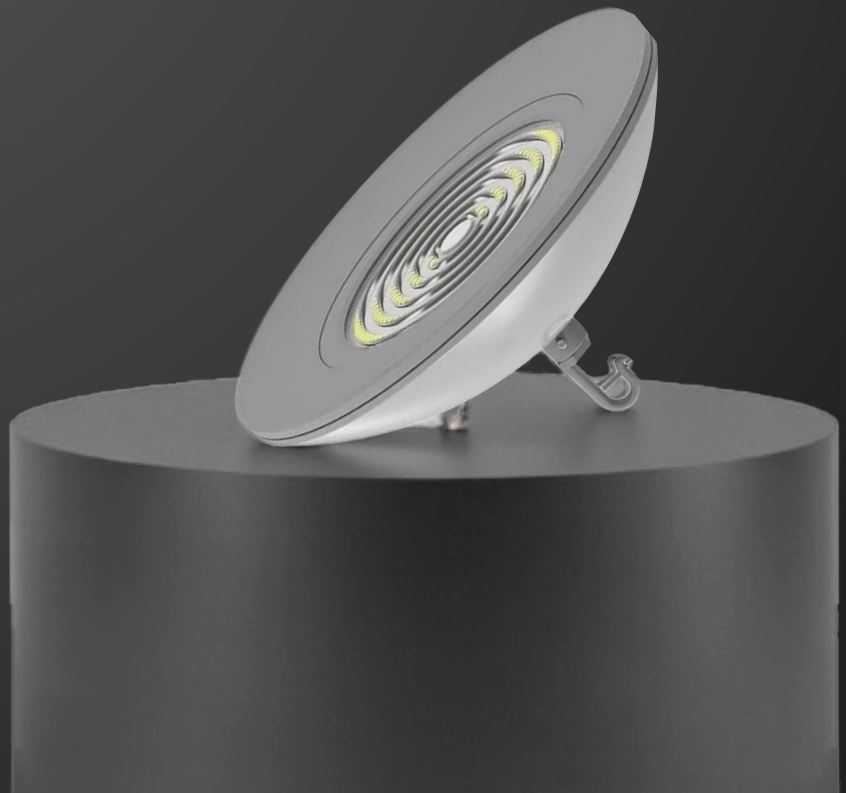

Beam Angle



60° 90° 120°

Applications

- Workshops & Assembly Lines
- Storage & Logistics
- Industrial & Commercial Halls
- Hangars
- Public Places - Airports & Stations

System Efficacy (lm/W)

>130lm/W

CRI

>80

CCT

4000K, 5700K

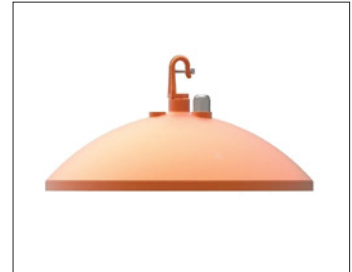
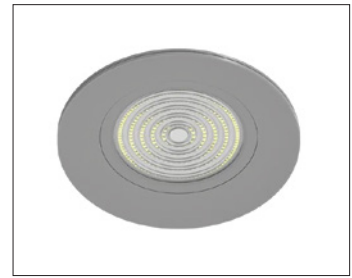

| Sizes | 400mm | 400mm | 400mm |
|---------|----------|----------|----------|
| Wattage | 100W | 150W | 200W |
| Lumen | 13,000lm | 19,500lm | 26,000lm |

Product Dimensions

Ø 400 x 197 mm

Product Impression

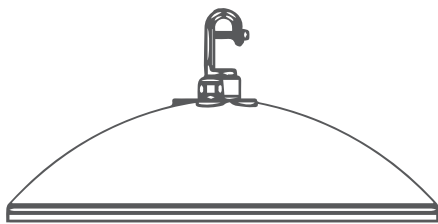

SDCM

<5 steps

Dimmable

ON/OFF , Dimmable 1-10V

Material

Aluminium + PC

Lamp Lumen Lifetime

50,000hrs @ L70/B50



05

COMFOLINE WATERPROOF IP65

Introducing LEDOS Comfoline WaterProof IP65, a beacon of reliability in industrial and commercial lighting solutions. Engineered to thrive in rugged and harsh environments, this Waterproof LED luminaire is a testament to durability and performance. Designed to withstand water and dust challenges, the Comfoline ensures uncompromised safety in the most demanding settings. Its robust impact resistance, coupled with a compact design, makes it a stalwart companion in environments where resilience is non-negotiable.

With standard lumen outputs available for selection, this luminary caters to diverse lighting needs. Experience excellence in illumination with its exceptional light beam spread, ensuring uniform brightness across every inch of your space. Elevate your industrial or commercial setting with confidence, knowing that the Comfoline is not just a light source but a testament to cutting-edge engineering.



Beam Angle



120°

Applications

- Parking Lots
- Garages
- Underpasses
- Workshops

System Efficacy (lm/W)

>130lm/W

CRI

>80

CCT

4000K, 5700K



| Sizes | 600mm | 1200mm | 1200mm |
|---------|---------|---------|---------|
| Wattage | 18W | 36W | 60W |
| Lumen | 2,340lm | 4,680lm | 7,800lm |

Product Dimensions

Ø 600 x 90 x 74 mm

Ø 1200 x 90 x 74 mm

Product Impression



SDCM

<5 steps

Dimmable

ON/OFF

Material

PC Body

Lamp Lumen Lifetime

50,000hrs @ L70/B50

UGR

👁️⁺ <22

IP65



06

EASYCOMFO TUBE WATERPROOF IP65

Introducing the EasyComfo Tube WaterProof IP65, a pinnacle of resilience and aesthetics in industrial and commercial lighting. Specially crafted to thrive in rugged and harsh environments, this Waterproof LED luminary sets a new standard for durability. Addressing water and dust safety concerns with unwavering confidence, the EasyComfo Tube ensures a secure and reliable lighting solution in the most challenging settings. Its robust impact resistance, coupled with a sleek tubular design, not only fortifies against external elements but also adds a touch of contemporary aesthetics to your space.

Experience brilliance like never before, as the EasyComfo Tube excels in light production, creating an ambiance that is both functional and visually stunning. Elevate your workspace with a lighting solution that transcends the ordinary.



Beam Angle



160°

Applications

- Parking Lots
- Garages
- Underpasses
- Workshops

System Efficacy (lm/W)

>130lm/W

CRI

>80 & >90

CCT

4000K, 5700K

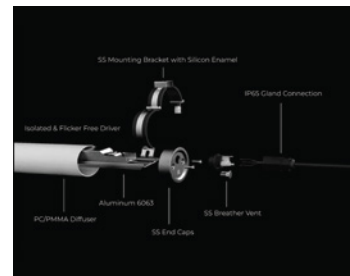

| Sizes | 600mm | 1200mm |
|---------|---------|---------|
| Wattage | 20W | 40W |
| Lumen | 2,600lm | 5,200lm |

Product Dimensions

Ø 75 x 552 mm

Ø 75 x 1152 mm

Product Impression

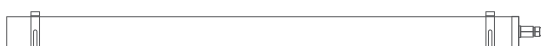

SDCM

<5 steps

Dimmable

ON/OFF

Material

Aluminium + Stainless Steel + PC

Lamp Lumen Lifetime

50,000hrs @ L70/B50

UGR

⁺ <22



07

LUXILED FLOODLIGHT

Introducing the EasyComfo Tube WaterProof IP65, a pinnacle of resilience and aesthetics in industrial and commercial lighting. Specially crafted to thrive in rugged and harsh environments, this Waterproof LED luminary sets a new standard for durability. Addressing water and dust safety concerns with unwavering confidence, the EasyComfo Tube ensures a secure and reliable lighting solution in the most challenging settings. Its robust impact resistance, coupled with a sleek tubular design, not only fortifies against external elements but also adds a touch of contemporary aesthetics to your space.

Experience brilliance like never before, as the EasyComfo Tube excels in light production, creating an ambiance that is both functional and visually stunning. Elevate your workspace with a lighting solution that transcends the ordinary.vv



Beam Angle

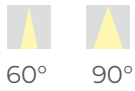

60° 90°

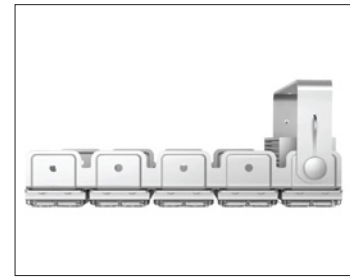

Applications

- Public Areas
- Warehoused
- Security Lighting
- Outdoor Billboards
- Garden Areas
- Facade Illumination



System Efficacy (lm/W)

>110 ~ 130lm/W



CRI

>70, >80

CCT

3000K, 4000K, 57000K

| Sizes | 1 Module | 1 Module | 2 Module | 3 Module | 4 Module | 5 Module |
|---------|----------|----------|----------|----------|----------|----------|
| Wattage | 30W | 50W | 100W | 150W | 200W | 250W |
| Lumen | 3,900lm | 6,500lm | 12,000lm | 18,000lm | 25,500lm | 30,000lm |

Product Dimensions

- Ø 80 x 360 x 179 mm
- Ø 207 x 360 x 120 mm
- Ø 240 x 360 x 120 mm
- Ø 320 x 360 x 120 mm
- Ø 400 x 360 x 120 mm

SDCM

<5 steps

Dimmable

ON/OFF

Material

Aluminum

Product Impression

Lamp Lumen Lifetime

50,000hrs @ L70/B50



08

LUX COMFO FLOODLIGHT

Introducing the EasyComfo Tube WaterProof IP65, a pinnacle of resilience and aesthetics in industrial and commercial lighting. Specially crafted to thrive in rugged and harsh environments, this Waterproof LED luminary sets a new standard for durability. Addressing water and dust safety concerns with unwavering confidence, the EasyComfo Tube ensures a secure and reliable lighting solution in the most challenging settings. Its robust impact resistance, coupled with a sleek tubular design, not only fortifies against external elements but also adds a touch of contemporary aesthetics to your space.

Experience brilliance like never before, as the EasyComfo Tube excels in light production, creating an ambiance that is both functional and visually stunning. Elevate your workspace with a lighting solution that transcends the ordinary.



Beam Angle

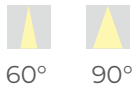

60° 90°

Applications

- Parking Lots
- Warehouse
- Security Lighting
- Outdoor Billboards
- Garden Areas
- Facade Illumination

System Efficacy (lm/W)

>100lm/W

CRI

>70, >80

CCT

3000K, 4000K, 5700K



| Sizes | 1 Module | 2 Module | 3 Module | 3 Module | 4 Module | 4 Module |
|---------|----------|----------|----------|----------|----------|----------|
| Wattage | 30W | 50W | 100W | 150W | 200W | 250W |
| Lumen | 3,000lm | 5,000lm | 10,000lm | 15,000lm | 20,000lm | 25,000lm |

Product Dimensions

- Ø 136 x 111 x 26 mm
- Ø 178 x 136 x 29 mm
- Ø 245 x 195 x 30 mm
- Ø 315 x 236 x 32 mm
- Ø 380 x 278 x 38 mm
- Ø 436 x 336 x 48 mm

Product Impression

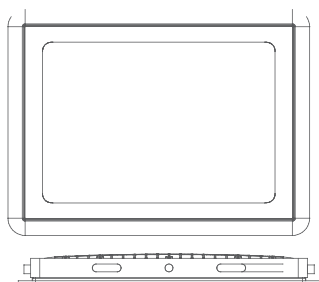

SDCM

<5 steps

Dimmable

ON/OFF

Material

Aluminium

Lamp Lumen Lifetime

50,000hrs @ L70/B50



09

SOLANA LED STREET LIGHT

Introducing the Solana LED Streetlight, a beacon of safety and sophistication designed to transform roads and pathways into brilliantly illuminated thoroughfares. Tailored for both industrial and commercial use, this streetlight is a testament to cutting-edge technology and meticulous engineering, ensuring optimal visual conditions for road users at night. With an outstanding light spread, the Solana LED Streetlight reveals every crucial feature of roads and traffic, prioritizing the safety and comfort of pedestrians, cyclists, and drivers alike.

Experience excellence in light production with standard lumen outputs catering to all types of carriageways, from M1 to M6 road types. Choose excellence, choose Solana for streets that shine with brilliance and safety, making every journey a well-lit and secure experience.



Beam Angle

150° x 70°

Applications

- Street Light Illumination
- Residential Road Lighting
- Parking Lots
- Industrial Roads

System Efficacy (lm/W)

>150 ~ 160lm/W

CRI

>70, >80

CCT

4000K, 5700K



| Sizes | 543mm | 543mm | 577mm | 627mm | 627mm | 768mm | 768mm | 768mm |
|---------|---------|---------|----------|----------|----------|----------|----------|----------|
| Wattage | 30W | 60W | 90W | 120W | 150W | 180W | 210W | 240W |
| Lumen | 4,500lm | 9,500lm | 13,500lm | 18,000lm | 22,500lm | 27,000lm | 31,500lm | 36,000lm |

Product Dimensions

- Ø 576 x 209 x 89 mm
- Ø 593 x 263 x 89 mm
- Ø 646 x 263 x 89 mm
- Ø 709 x 315 x 89 mm
- Ø 812 x 315 x 89 mm

Product Impression

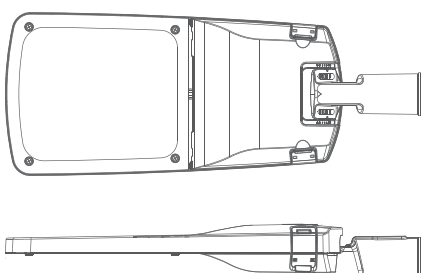

SDCM

<5 steps

Dimmable

ON/OFF, Programmable Driver

Material

Aluminum

Lamp Lumen Lifetime

50,000hrs @ L70/B50





LEDOS

LIGHTING SOLUTIONS

Redefining Lighting



+92 42 35847561 | +92 42 35847562



Office#410, 4th Floor, Al-Qader Heights,
New Garden Town Lahore, Pakistan



info@ledoslighting.com